

9.3 Description of the navigation keys and the status LEDs

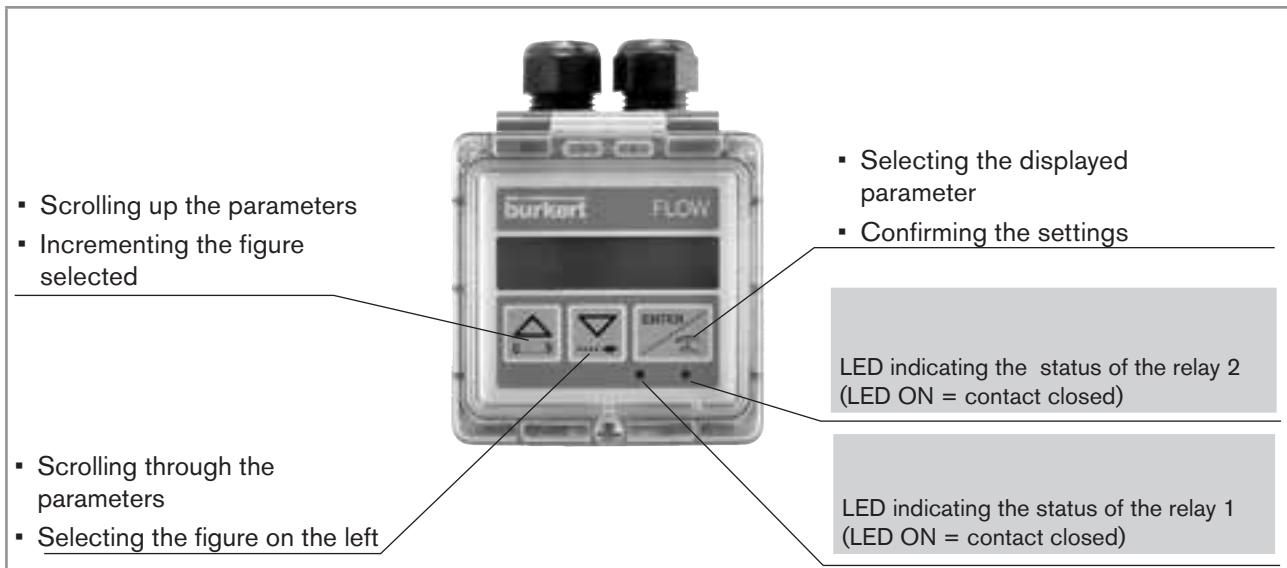

Fig. 55 : Description of the display

9.4 Using the navigation keys

You want to...	Press...
move between parameters within a level or a menu.	<ul style="list-style-type: none"> ▪ to go the next parameter. ▪ to go to the previous parameter.
access the Parameters menu.	+ simultaneously for 5 s, in the Process level
access the Test menu.	+ + simultaneously for 5 s, in the Process level
reset the daily totalizer, from the Process level.	+ simultaneously for 2 s, when the daily totalizer is displayed in the Process level
select the displayed parameter.	
confirm the displayed value.	
modify a numerical value.	<ul style="list-style-type: none"> ▪ to increase the blinking digit. ▪ to select the digit at the left of the blinking digit. ▪ + to move the decimal point.

9.5 Details of the Process level

This level is active by default when the device is energized.

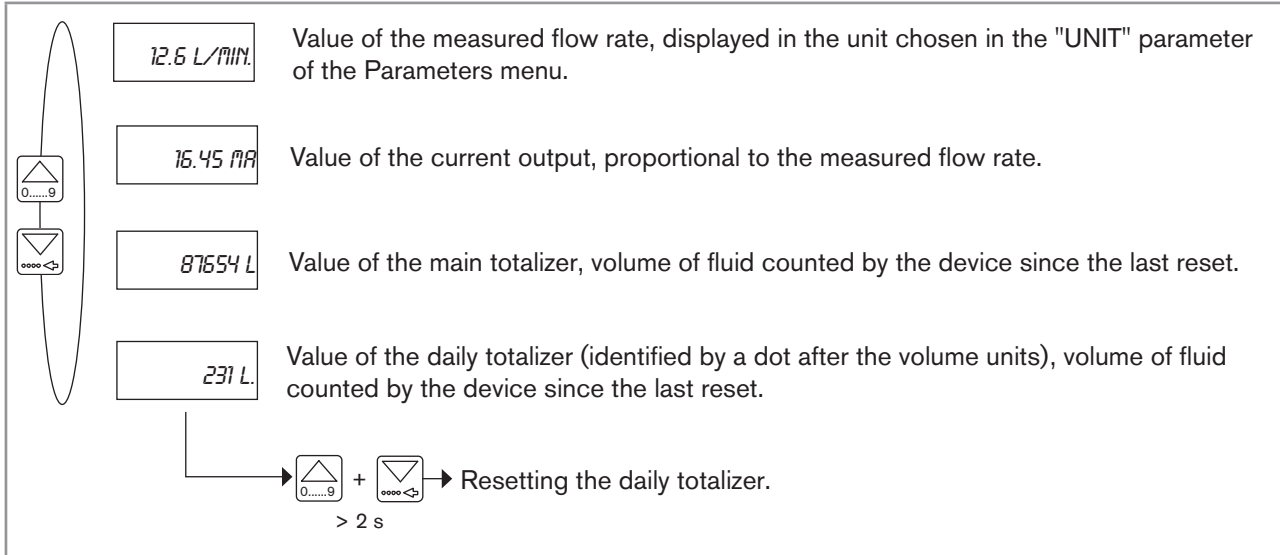

Fig. 56 : Diagram of the Process level

9.6 Details of the Parameters menu

To access the Parameters menu, simultaneously press keys for at least 5 s.

This menu comprises the following configurable parameters:

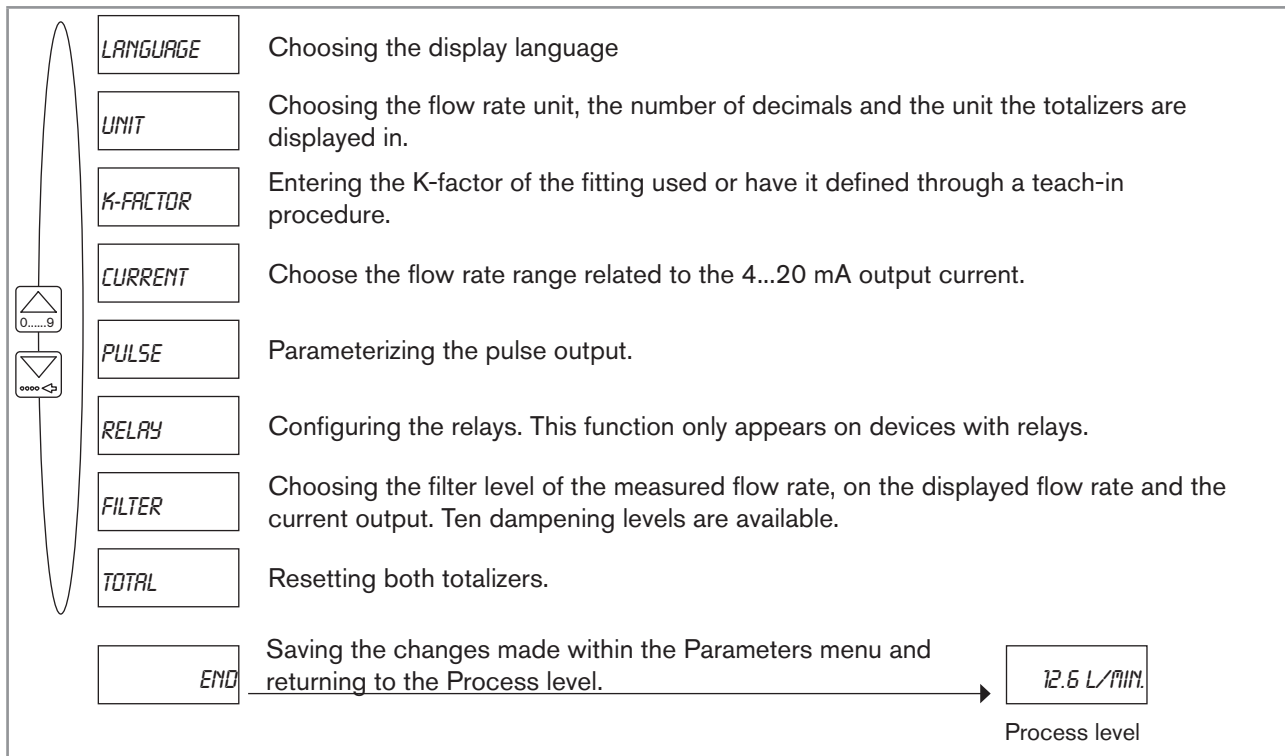

Fig. 57 : Diagram of the Parameters menu

9.6.1 Choosing the display language

When the device is energized for the first time, the display language is English.

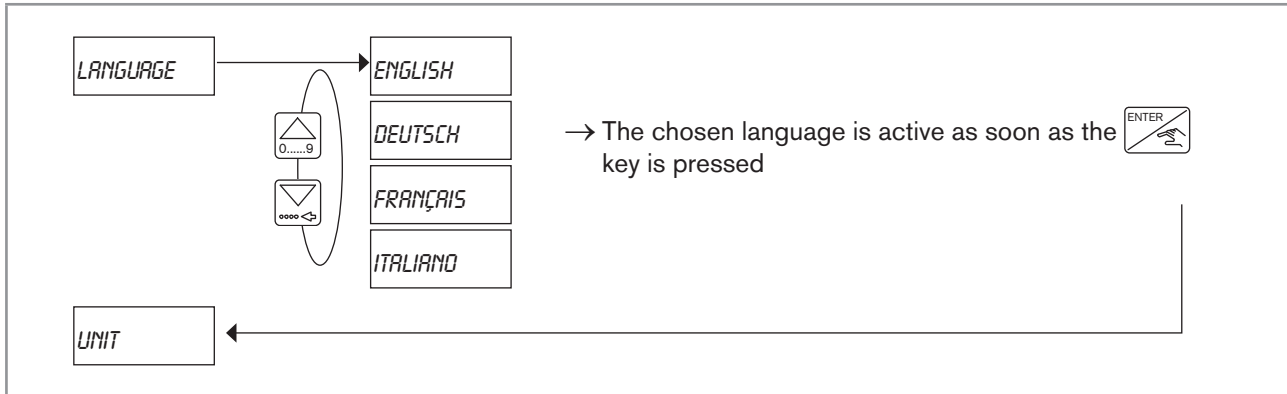



Fig. 58 : Diagram of the "LANGUAGE" parameter of the Parameters menu

→ If you do not want to adjust another parameter, go to the "END" parameter of the Parametersmenu and press  to save the settings and go back to the Process level.

9.6.2 Choosing the flow rate units, the number of decimals and the units of the totalizers

The max. flow rate that can be displayed depends on the number of decimals chosen:



- 9999 if the number of decimals = 0.
- 999,9 if the number of decimals = 1.
- 99,99 if the number of decimals = 2.
- 9,999 if the number of decimals = 3.

The max. flow rate that can be displayed by the totalizers depends on the volume unit chosen:



- 9 999 999 if the volume unit chosen is "litre";
- 999 999 if the volume unit chosen is "m³" or "gallon".



- When the flow rate unit is changed convert the flow rate values set within the "CURRENT", "PULSE" and "RELAYS" parameters of the Parameters menu.

The "UNIT" parameter makes it possible to choose:

- the flow rate units;
- a fixed number of decimals (choice 0, 1, 2 or 3) to display the flow rate in the Process level;
- the volume units of the totalizers if the unit previously chosen is in litres, in m³ or in gallons.

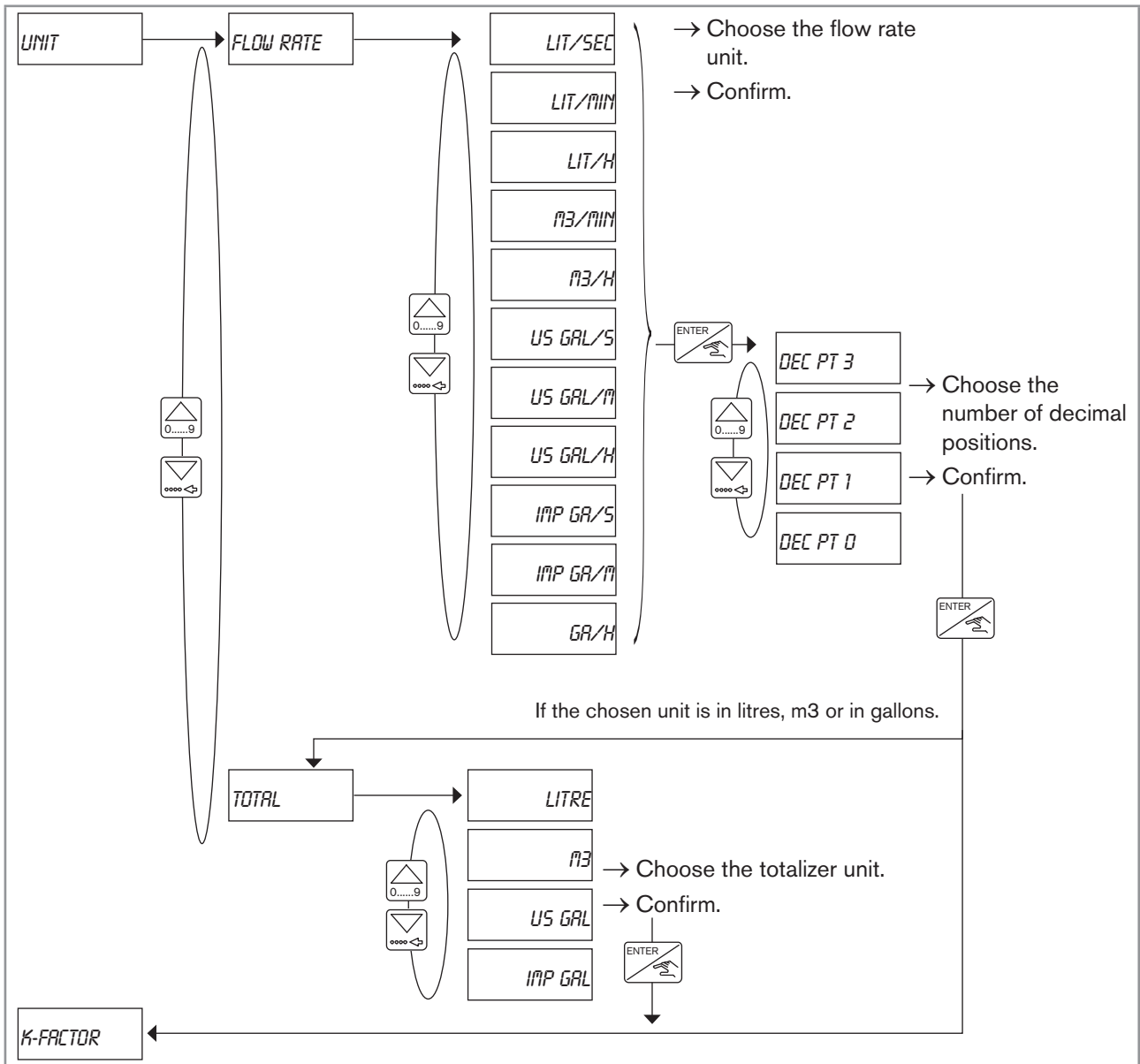

Fig. 59 : Diagram of the "UNIT" parameter of the Parameters menu

→ If you do not want to adjust another parameter, go to the "END" parameter of the Parameters menu and press to save the settings and go back to the Process level.

9.6.3 Entering the K-factor of the fitting used

The device determines the flow rate in the pipe using the fitting K-factor.

The K-factor of the fitting used can be entered here. The device may also determine the K-factor using a teach-in procedure: see Fig. 61.



The K-factor of the fitting used is in the Operating Instructions of the fitting.

The Operating Instructions of the Bürkert fittings can be found on the CD delivered with the device or is available on the internet at: www.burkert.com.

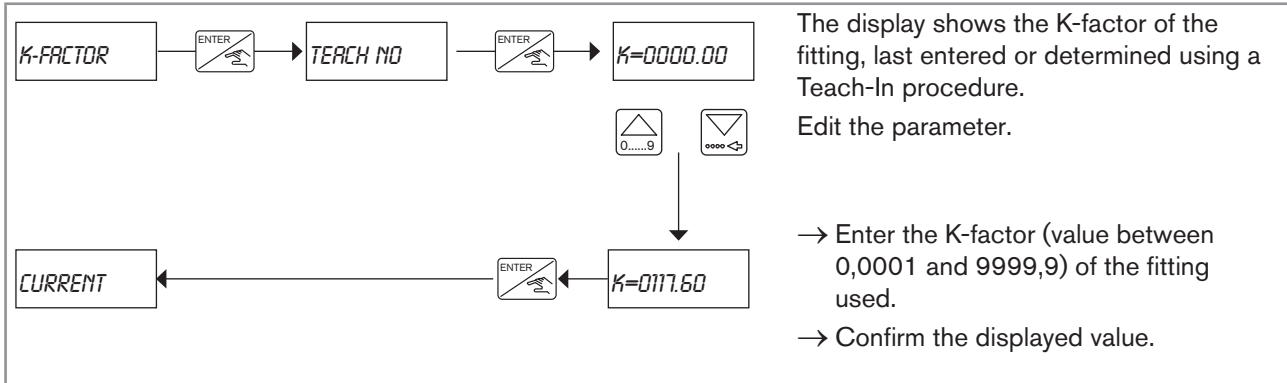

Fig. 60 : Entering the K-factor of the fitting used

The teach-in is done depending on a known volume.

- Prepare a tank with a known volume.
- Stop the fluid circulation.
- Confirm "TEACH Y.": "FILL END." is displayed.

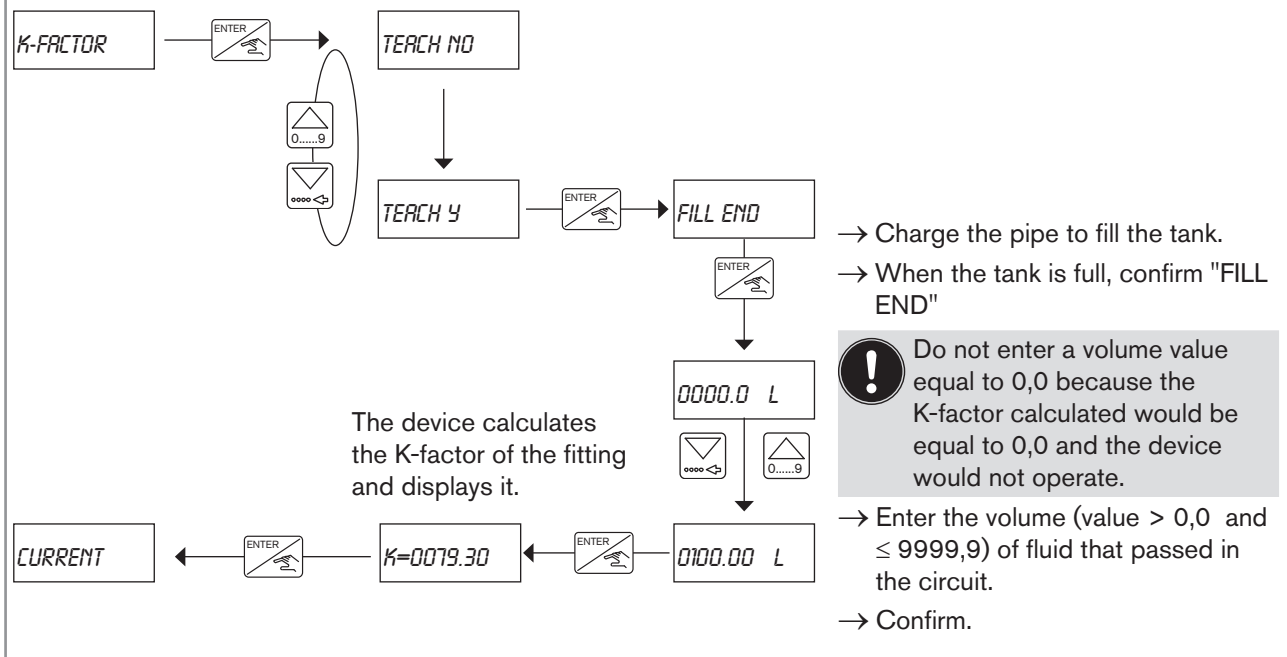

Fig. 61 : Teach-in procedure depending on a volume

→ If you do not want to adjust another parameter, go to the "END" parameter of the Parameters menu and press to save the settings and go back to the Process level.

9.6.4 Configuring the current output

The 4...20 mA output provides an electrical current, the value of which reflects the flow rate measured by the device.

Example of relation between the measuring range and the current output:

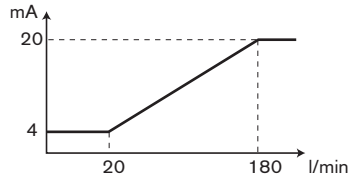

→ To invert the output signal, give a lower flow rate value to the 20 mA current value than to the 4 mA current value.

→ To disable the current output, set both range bounds, 4 and 20 mA, to zero. In this case the output delivers a constant current of 4 mA.

The units and number of decimal digits are those set within the "UNIT" parameter for the display of the current output values.

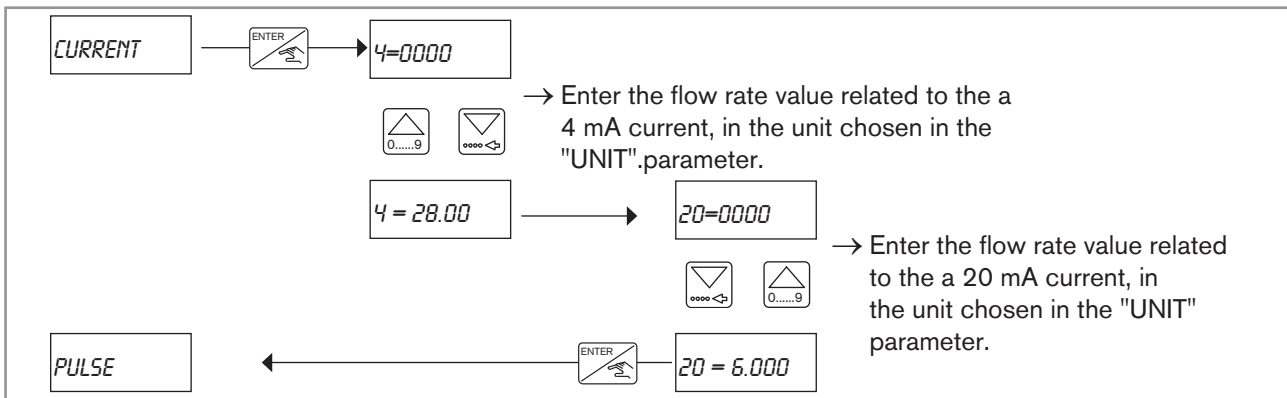

Fig. 62 : Configuration of the current output

→ If you do not want to adjust another parameter, go to the "END" parameter of the Parameters menu and press to save the settings and go back to the Process level.

9.6.5 Configuring the pulse output

This parameter makes it possible to enter the volume of liquid related to a pulse.

MAN 1000215667 EN Version: D Status: RL (released | freigegeben) printed: 24.10.2016

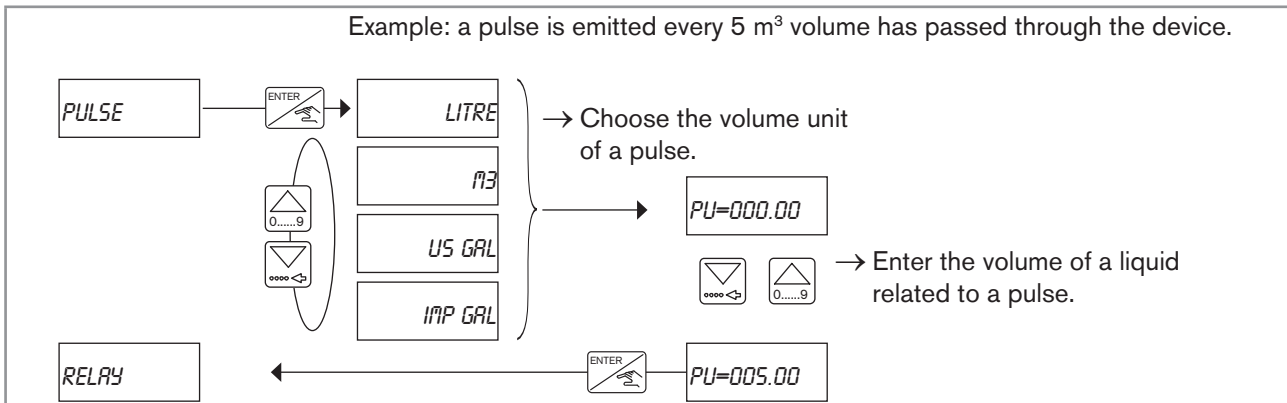

Fig. 63 : Configuration of the pulse output

! If the message "PU H LIM" or "PU L LIM" is displayed, see chap. [10.3](#).

→ If you do not want to adjust another parameter, go to the "END" parameter of the Parameters menu and press to save the settings and go back to the Process level.

9.6.6 Configuring the relays

This parameter makes it possible to set the switching thresholds and the operating behaviour, inverted or not, of each relay.

! Enter values such as 1- ≤ 1+ and/or 2- ≤ 2+.

Both relays work in an hysteresis operating.

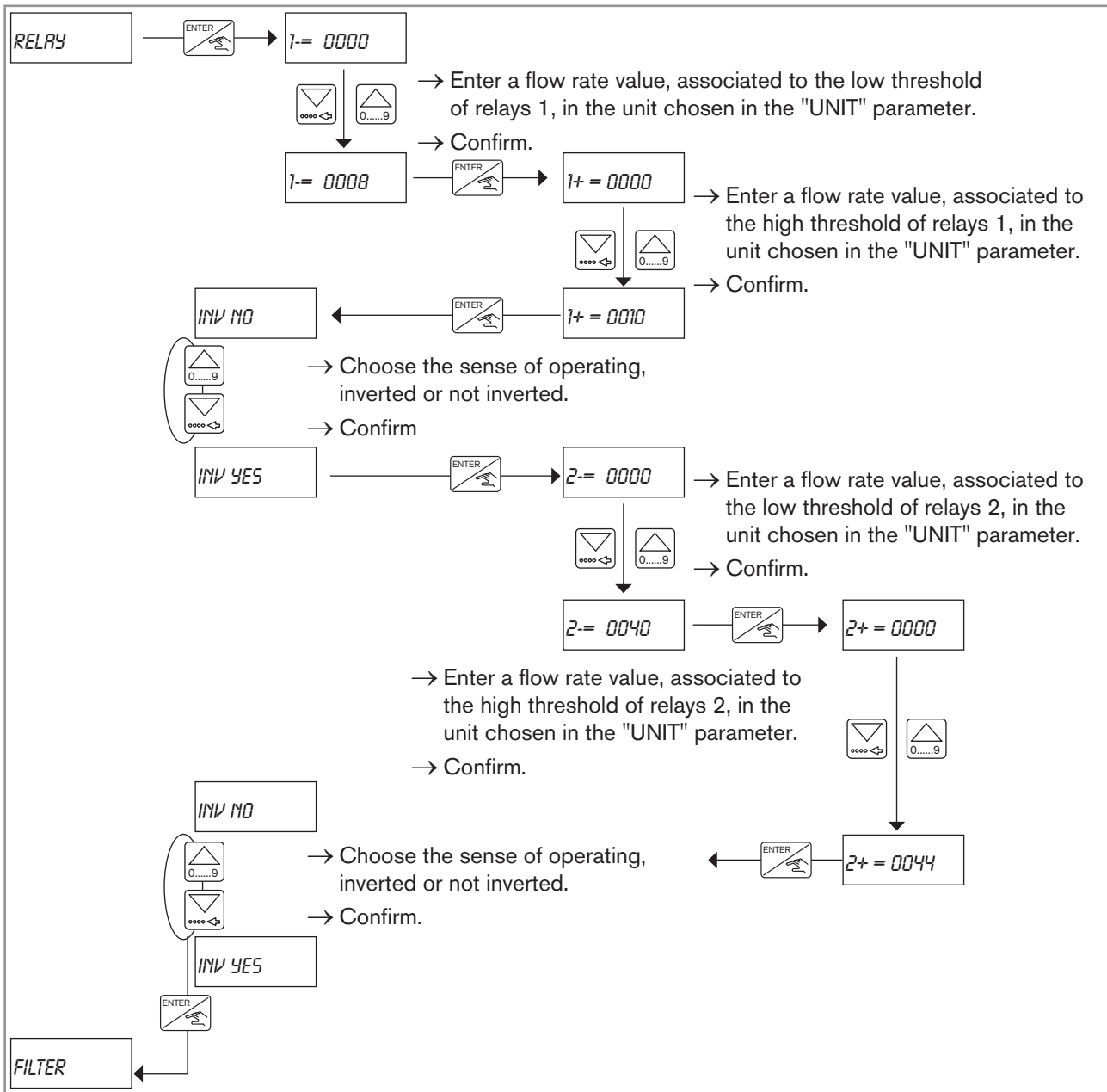

Fig. 64 : Configuration of the relays threshold in hysteresis operating

→ If you do not want to adjust another parameter, go to the "END" parameter of the Parameters menu and press



to save the settings and go back to the Process level.

MAN 1000215667 EN Version: D Status: RL (released | freigegeben) printed: 24.10.2016

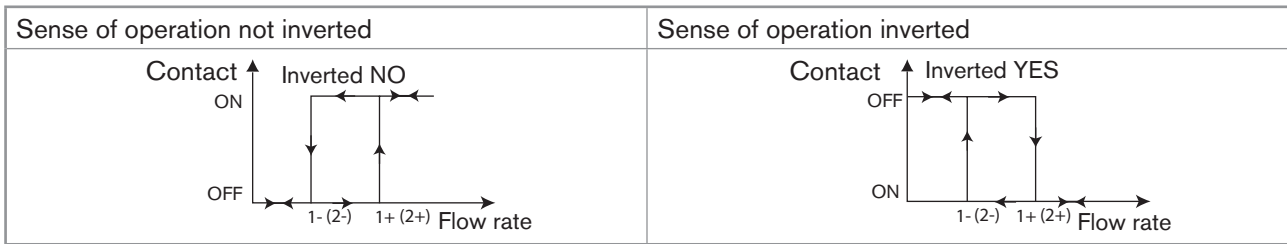

Fig. 65 : Hysteresis operating

9.6.7 Configuring the filter of the measured flow rate

This parameter makes it possible to dampen the fluctuations:

- of the display;
- of the current output.

Ten filters are available.

The following table gives the response time for each filter (10% to 90%):

FILTER	Response time	FILTER	Response time
0	0,15 s	5	6 s
1	0,7 s	6	10 s
2	1,4 s	7	19 s
3	2,5 s	8	33 s
4	3,5 s	9	50 s

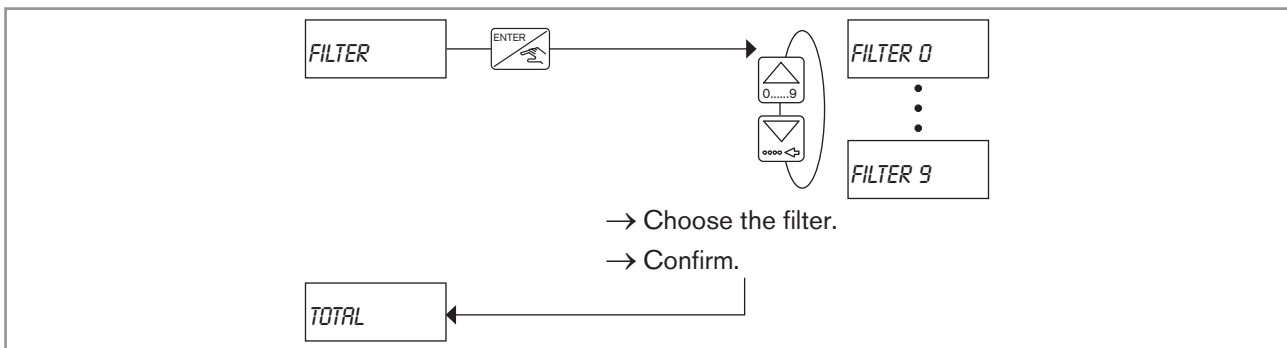

Fig. 66 : Diagram of the "FILTER" parameter of the Parameters menu

→ If you do not want to adjust another parameter, go to the "END" parameter of the Parameters menu and press



to save the settings and go back to the Process level.

9.6.8 Resetting both totalizers

This parameter makes it possible to reset both totalizers.

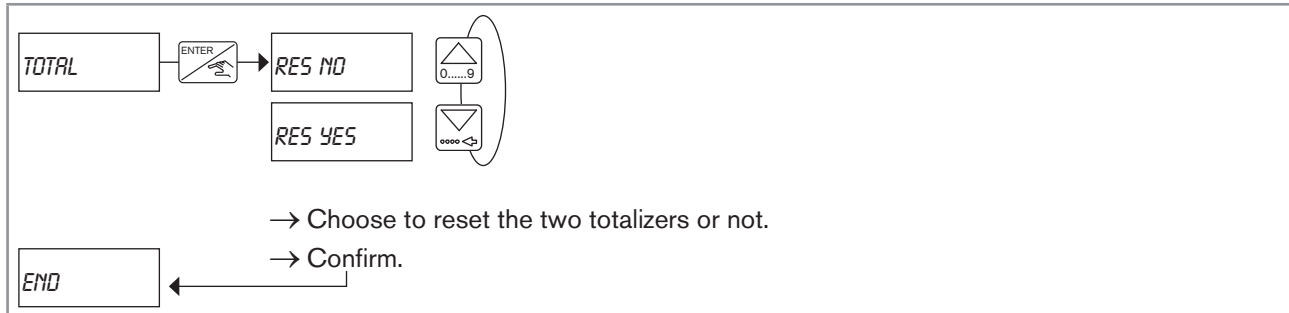

Fig. 67 : Diagram of the "TOTAL" parameter of the Parameters menu

The daily totalizer can be reset from the Process level. See chap. 9.4.

→ If you do not want to adjust another parameter, go to the "END" parameter of the Parameters menu and press to save the settings and go back to the Process level.

9.7 Details of the Test menu

To access the Test menu, simultaneously press keys for at least 5 s.

This menu comprises the following configurable parameters:

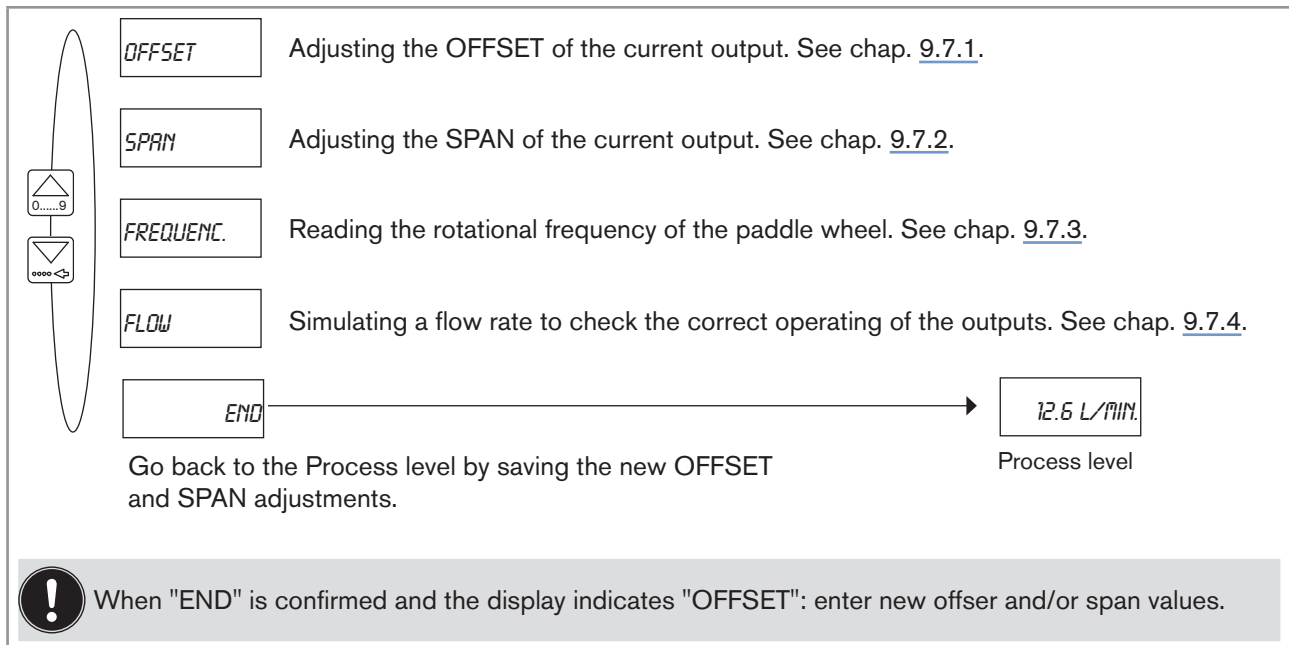

Fig. 68 : Diagram of the Test menu

MAN 1000215667 EN Version: D Status: RL (released | freigegeben) printed: 24.10.2016

9.7.1 Adjusting the OFFSET of the current output

This parameter makes it possible to adjust the 4 mA current value transmitted on the 4...20 mA output.

→ Connect a multimeter into the measurement loop.

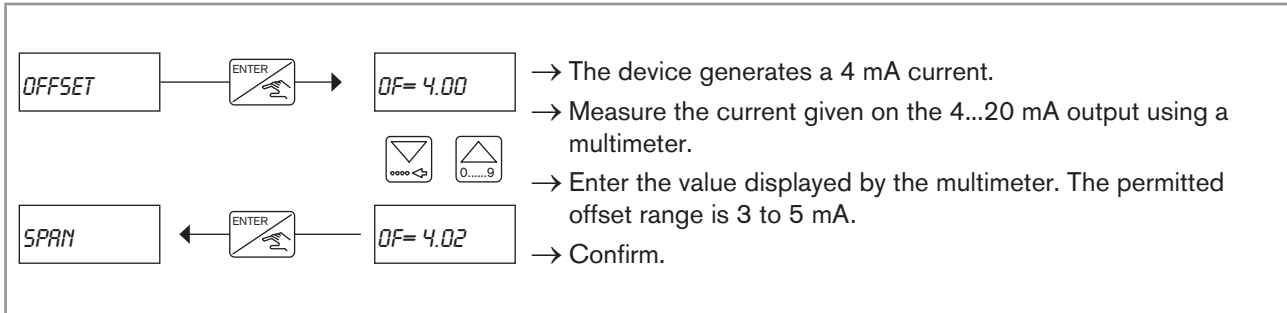



Fig. 69 : Adjustment of the OFFSET

Fig. 70 :

→ Adjust the default 20 mA current value: see chap. 9.7.2.

! The adjusted value of the default 4 mA value (parameter "OFFSET") is taken into account when leaving the parameter "SPAN".

→ If you do not want to adjust another parameter, go to the "END" parameter of the Test menu and press  to save the settings and go back to the Process level.

9.7.2 Adjusting the SPAN of the current output

This parameter makes it possible to adjust the 20 mA current value transmitted on the 4...20 mA output.

→ Connect a multimeter into the measurement loop.

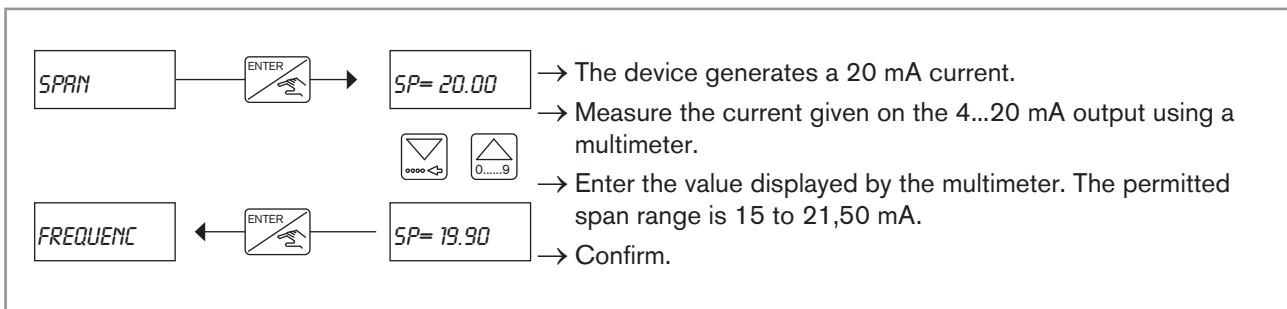



Fig. 71 : Adjustment of the SPAN

→ If you do not want to adjust another parameter, go to the "END" parameter of the Test menu and press  to save the settings and go back to the Process level.

9.7.3 Reading the rotational frequency of the paddle wheel

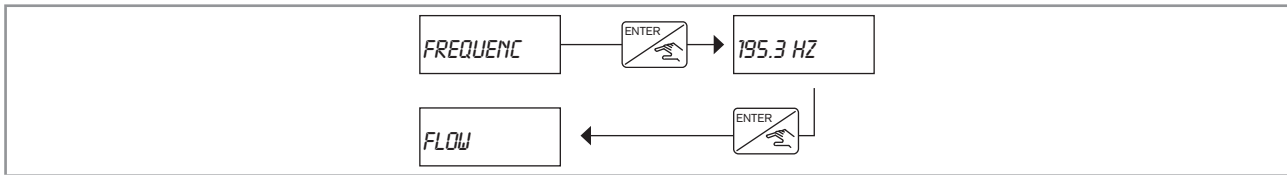

Fig. 72 : Diagram of the "FREQUENC." parameter of the Test menu

→ If you do not want to adjust another parameter, go to the "END" parameter of the Test menu and press to save the settings and go back to the Process level.

9.7.4 Checking the outputs behaviour

This parameter makes it possible to simulate a flow rate in order to check that the outputs are behaving as expected by the configuration made.

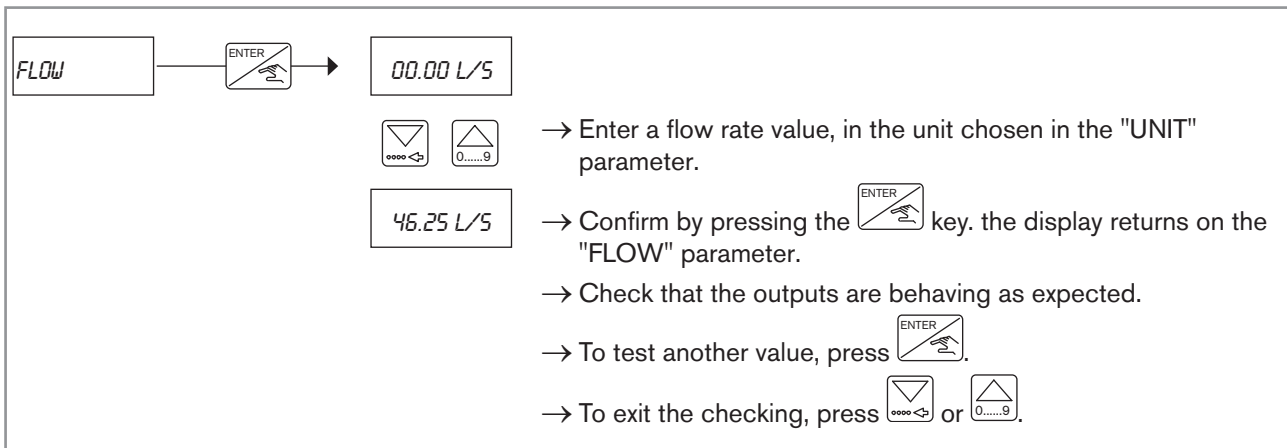

Fig. 73 : Diagram of the "FLOW" parameter of the Test menu

→ If you do not want to adjust another parameter, go to the "END" parameter of the Test menu and press to save the settings and go back to the Process level.

10 MAINTENANCE AND TROUBLESHOOTING

10.1 Safety instructions



DANGER

Danger due to electrical voltage.

- ▶ Shut down the electrical power source of all the conductors and isolate it before carrying out work on the system.
- ▶ Observe all applicable accident protection and safety regulations for electrical equipment.

Risk of injury due to high pressure in the installation.

- ▶ Stop the circulation of fluid, cut off the pressure and drain the pipe before loosening the process connections.

Risk of injury due to high fluid temperatures.

- ▶ Use safety gloves to handle the device.
- ▶ Stop the circulation of fluid and drain the pipe before loosening the process connections.

Risk of injury due to the nature of the fluid.

- ▶ Respect the prevailing regulations on accident prevention and safety relating to the use of hazardous products.



WARNING

Risk of injury due to nonconforming maintenance.

- ▶ Maintenance must only be carried out by qualified and skilled staff with the appropriate tools.
- ▶ Guarantee a defined or controlled restarting of the process after a power supply interruption.

10.2 Cleaning the device

The device can be cleaned with a cloth dampened with water or a detergent compatible with the materials the device is made of.

Please feel free to contact your Bürkert supplier for any additional information.